

TTP-244M Pro / TTP-342M Pro
TTP-244ME Pro / TTP-342ME Pro

**THERMAL TRANSFER / DIRECT THERMAL
BAR CODE PRINTER**

**USER'S
MANUAL**

Copyright Information

©2011 TSC Auto ID Technology Co., Ltd,
The copyright in this manual, the software and firmware in the printer described therein are owned by TSC Auto ID Technology Co., Ltd, All rights reserved.

Windows is a registered trademark of Microsoft Corporation.
All other trademarks are the property of their respective owners.

Information in this document is subject to change without notice and does not represent a commitment on the part of TSC Auto ID Technology Co. No part of this manual may be reproduced or transmitted in any form or by any means, for any purpose other than the purchaser's personal use, without the expressed written permission of TSC Auto ID Technology Co.

Agency Compliance and Approvals



CE CLASS A
EN55022:2006+A1:2007
EN50024:1998+A1:2001+A2:2003
EN61000-4-2:2008, EN61000-4-3: 2008, EN61000-4-4: 2004
EN 60950-1:2006+A11:2009 (LVD)



GB9254-2008 (CLASS A)
GB4943-2001
GB17625.1-2003

此为A级产品，在生活环境中，该产品可能会造成无线电干扰，
在这种情况下，可能需要用户对干扰采取切实可行的措施。

A급기기

(업무용 정보통신기기)

이 기기는 업무용으로 전자파 적합등록을 한 기기이오니, 판매자 또는 사용자는 이 점을 주위하시기 바라며, 만약 잘못 판매 또는 구입하였을 때에는 가정용으로 교환하시기 바랍니다.

CONTENTS

1. PRODUCT INTRODUCTION.....	1
2. GETTING STARTED.....	2
2.1 Equipment Checklist	2
2.2 Printer Parts.....	3
2.3 Buttons and Indicators	6
3. SET UP	8
3.1 Setting up the Printer	8
3.2 Loading the Ribbon.....	9
3.3 Loading the Label	13
3.4 Loading Media in Peel-off Mode (Option)	16
3.5 Loading Media in Cutter Mode (Option).....	18
4. POWER-ON UTILITIES	19
4.1 Self Test Utility.....	19
4.2 Gap Sensor Calibration Utility.....	22
4.3 Printer Initialization	23
5. DIAGNOSTIC TOOL.....	24
5.1 Start the Diagnostic Tool	24
5.2 Printer Function	25
6. TROUBLESHOOTING.....	26
7. MAINTENANCE.....	27
REVISE HISTORY.....	28
APPENDIX A MENU CONTROL FLOWCHART (OPTION).....	1

1. PRODUCT INTRODUCTION

Thank you very much for purchasing this bar code printer. The attractive printer delivers superior performance at an economical price. Both powerful and easy-to-use, this printer is your best choice.

The printer offers both thermal transfer and direct thermal printing at user selectable speeds: either 1.5, 2.0, 3.0 and 4.0 IPS (Inch Per Second) for 203 DPI model; 1.0, 1.5 and 2.0 IPS for 300 DPI model. It can accept a wide range of media, including roll feed, die-cut, and fan-fold labels for both thermal transfer and direct thermal printing. All of the most frequently used bar code formats are available. Fonts and bar codes can be printed in any one of the four directions. This printer provides a choice of five different sizes of alphanumeric fonts. By using font multiplication, an even greater range of sizes is possible. Smooth fonts can be down-loaded from the user friendly, Windows labeling software. In addition, this printer is capable of independently executing BASIC programming functions, including arithmetic, logical operation, loop, flow-control and file management, among others. This programming capability provides the greatest efficiency in label printing.

2. GETTING STARTED

This printer has been specially packaged to withstand damage in the shipping process. However, for fear that unexpected damage might occur, upon receiving the bar code printer, carefully inspect the package and the device. In case of evident damage, contact the carrier directly to specify the nature and extent of the damage. Please retain the packaging materials in case you need to reship the printer.

2.1 Equipment Checklist

- One bar code printer unit
- One ribbon paper core for ribbon rewind spindle
- Two ribbon supply/rewind spindle (2 pcs)
- One USB interface cable
- One power cord
- One Windows labeling software/ Windows driver CD disk
- One quick start guide

Separately purchased items may also be included. These additional items may include:

- Labels
- Ribbons
- Stand-alone keyboard
- Cutter module
- Peel-off module

If any parts are missing, please contact the Customer Service Department of your purchased reseller or distributor.

2.2 Printer Parts

Front View

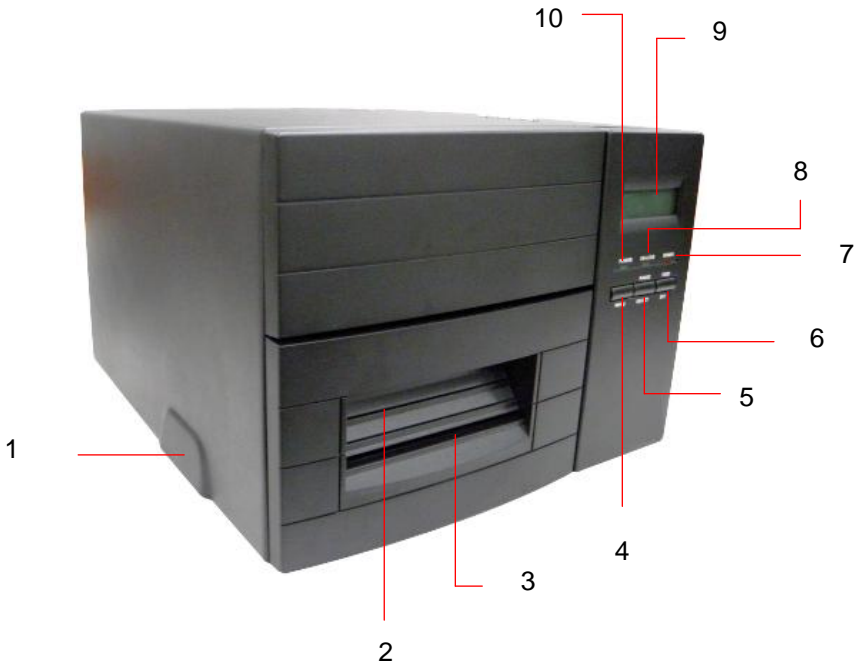

- 1. Printer cover/ Release handle
- 2. Label dispense opening
- 3. Liner opening (Option function)
- 4. MENU button (Option for E series)
- 5. PAUSE/ SELECT button
- 6. FEED/ SET button
- 7. Error indicator
- 8. On-line indicator
- 9. LCD display (Option for E series)
- 10. Power indicator

Interior View

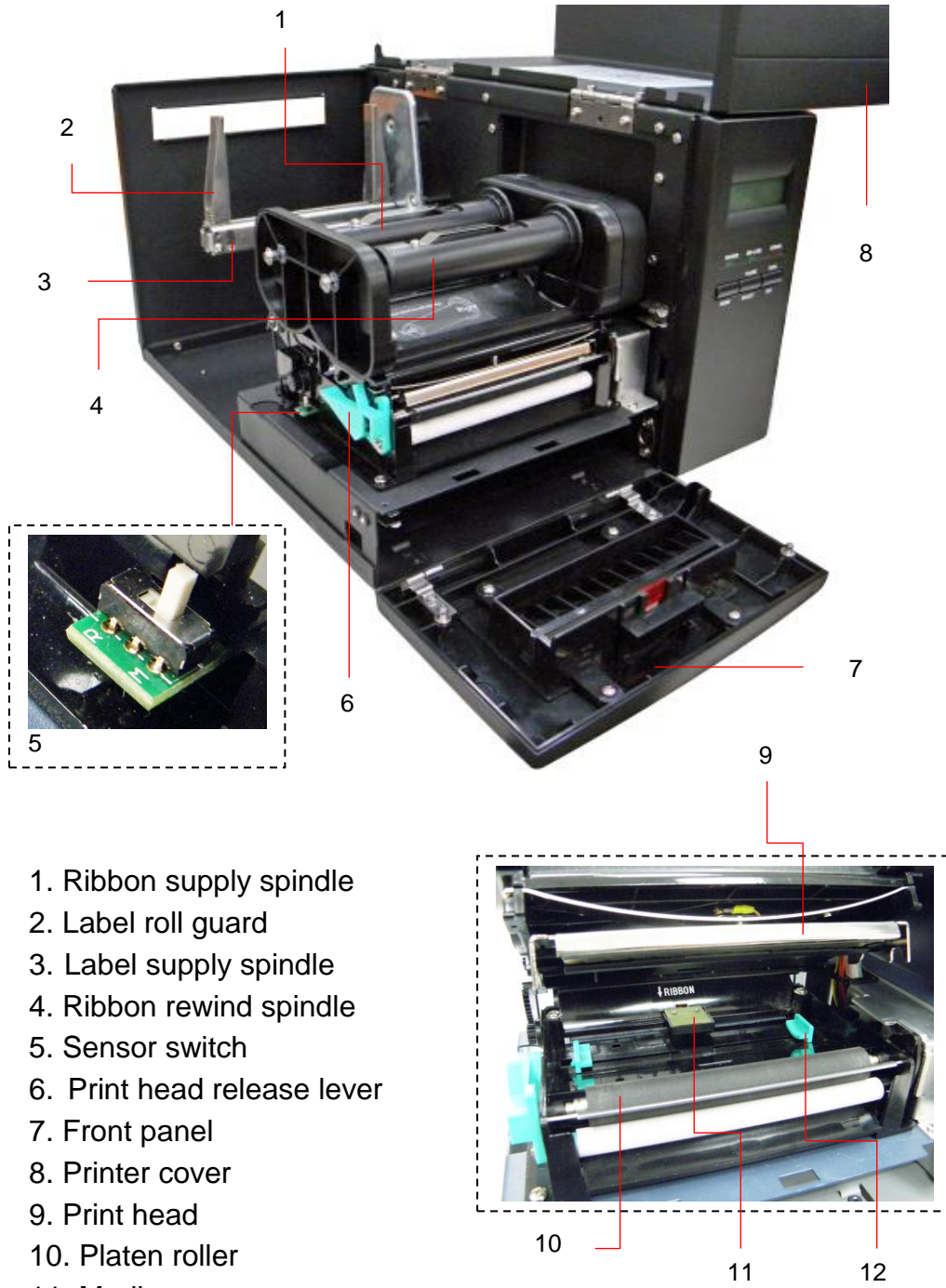

1. Ribbon supply spindle
2. Label roll guard
3. Label supply spindle
4. Ribbon rewind spindle
5. Sensor switch
6. Print head release lever
7. Front panel
8. Printer cover
9. Print head
10. Platen roller
11. Media sensor
12. Adjustable label guide

Rear View

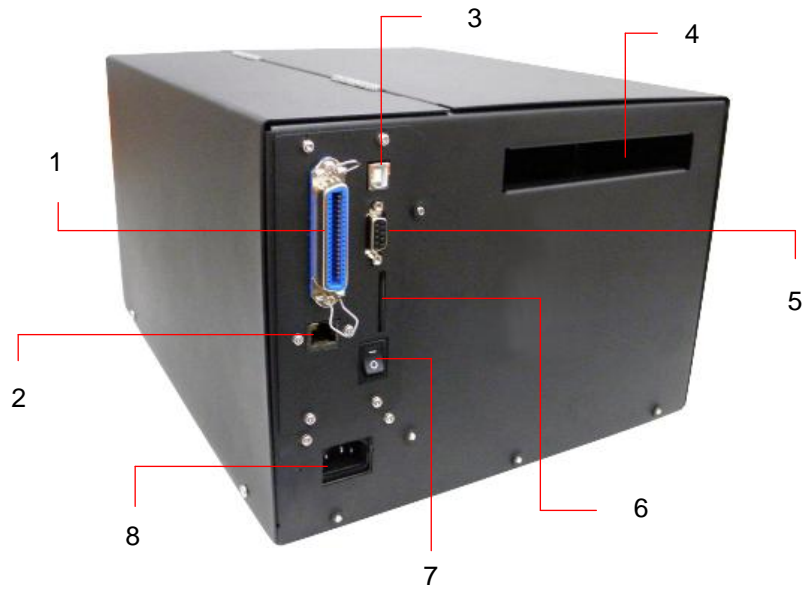

1. Centronics interface (Option for E series)
2. Ethernet interface (Option)
3. USB interface
4. Label insert opening (For use with external labels)
5. RS-232C interface connector
6. SD card socket
7. Power switch
8. Power cord socket

Note: The interface picture here is for reference only. Please refer to the specification for the interfaces availability.

2.3 Buttons and Indicators

POWER Indicator

The green **POWER** indicator illuminates when the power switch is turned on.

ON-LINE Indicator

The green **ON-LINE** indicator illuminates when the printer is ready to print. When the **PAUSE** button is pressed, the **ON-LINE** indicator will be flash.

ERROR Indicator (Error/Paper Empty)

The red **ERROR** indicator illuminates in the event of a printer error, such as paper empty, ribbon empty, out of memory, and so forth. For a full list of error messages, please refer to Section 4.2, Troubleshooting Guide.

MENU Button (Option function for E series)

Provided with a built-in menu, the printer allows the user to directly set printing parameters or view printer status on the LCD display panel. To enter the Menu mode, press the **MENU** button. Press the button over again to proceed from one menu item to another or to revert to the original Ready status. The menu is comprised of these major items: **Printer Info**, **File List**, **Memory Info**, **Date/Time**, and **Printer Setup**. Each of said items, in turn, is made up of a number of sub-items, which can be selected by pressing the **SELECT** button, or viewed or set by pressing the **SET** button. Refer to Appendix for the structure and operation logic of the menu.

PAUSE/SELECT Button

This button combines two functions: **PAUSE** if the printer is in the Ready status, or **SELECT** if in the Menu mode.(Option function for E series)

The **PAUSE** button allows the user to hold a print job and then resume the printing with a second depression of the button. By pressing the **PAUSE** button: (1) the printer stops at the completion of printing of the current label, (2) the **PAUSE** LED flashes, and (3) the printer holds all data in memory. This allows for trouble-free replacement of label stock and thermal transfer ribbon. A second depression of the **PAUSE** button will restart the printer.

Note: If the PAUSE button is held down for more than 3 seconds, the printer will be reset and all data of the previous printing job will be lost.

The **SELECT** button allows the user select for the sub-item to be processed. Once the sub-item has been selected, the user can change its setting by pressing the **SET** button. (Option function for E series)

FEED/SET Button

As does the **PAUSE/SELECT** button, this button also has dual functions: **FEED** and **SET**.

Press the **FEED** button for label to advance to the next print position.

Press the **SET** button to change parameter settings or view printer status on the LCD screen. (Option function for series)

3. SET UP

3.1 Setting up the Printer

1. Place the printer on a flat, secure surface.
2. Make sure the power switch is off.
3. Connect the printer to the computer mainframe with the provided printer cable.
4. Plug the power cord into the AC power cord socket at the rear of the printer, and then plug the power cord into a properly grounded receptacle.

Note: Please switch OFF printer power switch prior to plug in the power cord to printer power jack.

3.2 Loading the Ribbon

1. Open the printer cover and front panel.



2. Place an empty paper core onto the ribbon rewind spindle.

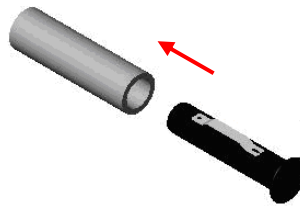

3. Insert the left side first. Mount the ribbon rewind paper core on the front hubs. Please be noted that the bigger hub side with 4 ribs must be installed toward the right side of ribbon mechanism.



4. Install a ribbon on the ribbon supply spindle. Mount the ribbon supply spindle on the rear hubs. Insert the left side first.



5. Please be noted that the bigger hub side with 4 ribs must be installed toward the right side of ribbon mechanism.



6. Disengage the printer carriage by pulling the print head release lever.

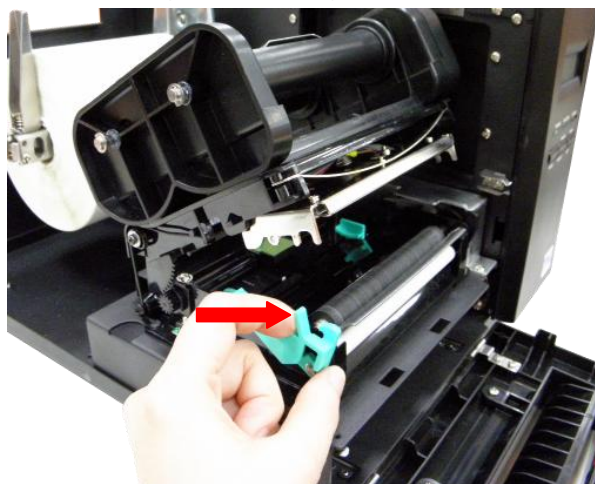

7. Following the direction of the ↓ **RIBBON** label, pull the ribbon leader to the front from beneath the printer carriage.



8. Attach the ribbon leader to the ribbon rewind paper core (with a tape).



5. Rotate the ribbon rewind roller until the ribbon overlaps the ribbon leader and stretches tight.

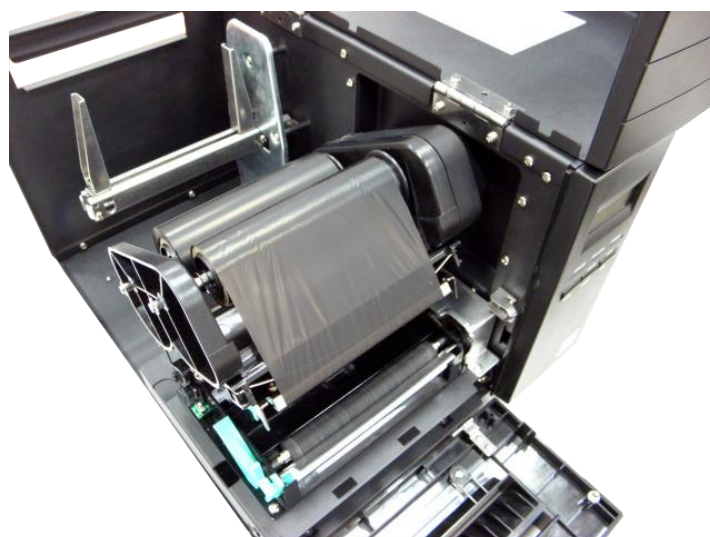

6. Engage the printer carriage.
7. Close the printer cover and press the **FEED** button until the green **ON-LINE** LED illuminates.

Note:

- ***When switched on, the printer will automatically detect whether ribbon is installed to set printer to direct thermal or thermal transfer mode. As such, to use thermal transfer mode, be sure to install the ribbon, the label, and engage the ribbon mechanism before you switch on the printer. To use direct thermal mode, install the label and engage the ribbon mechanism before switching on the printer.***
- ***Please refer to videos on [TSC YouTube](#) or driver CD.***

3.3 Loading the Label

1. Open the printer cover and front panel.



2. Lower the label roll guard to the horizontal position, slide the label stock into label roll spindle, and then flip back the label roll guard.



3. Disengage the printer carriage by pulling the print head release lever located to the left side of the platen.

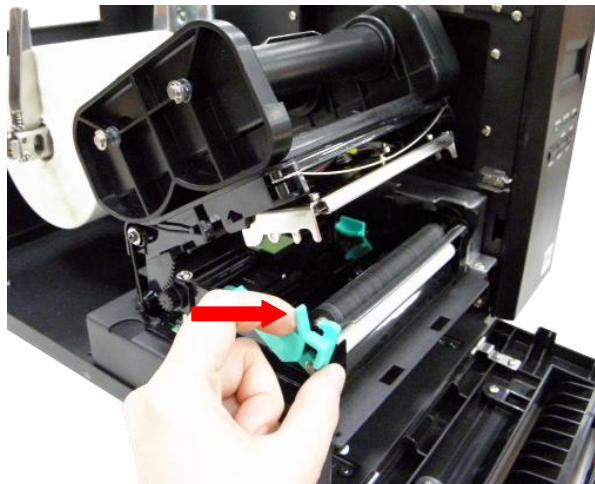

4. Install the label so that it goes (when using an external label roll mount: through the label feed slot) in the direction of the ↓ LABEL label and under the ribbon mechanism to lay upon the platen.



5. Adjust the label guide to fit the width of the media.

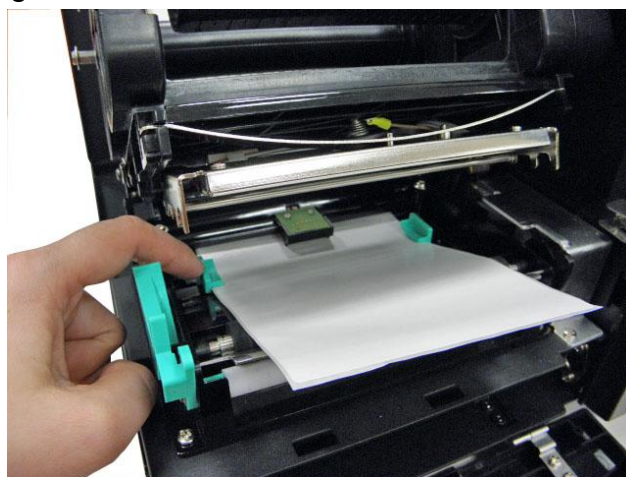

6. Engage the printer carriage.
7. Wind the label roll until it becomes adequately stretched for the intended purpose.
8. Select the using label type by sensor switch.
"M" for single column label
"R" for double column label

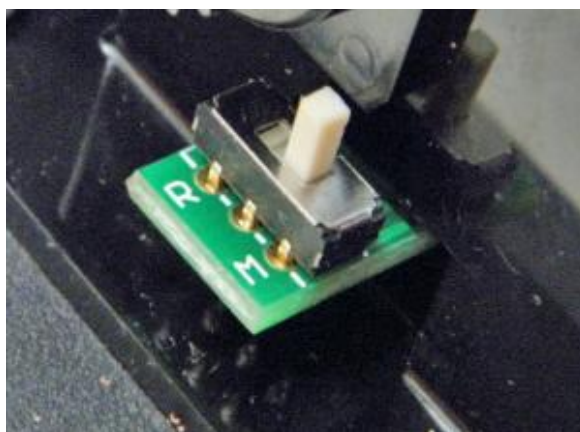

9. Close the printer cover and front panel.



10. Use “Diagnostic Tool” to set the media sensor type and calibrate the selected sensor. (Start the “Diagnostic tool” → Select the “Printer Configuration” tab → Click the “Calibrate Sensor” button) Please refer to the section 4.

Note:

- ***Please calibrate the gap/black mark sensor when changing the media.***
- ***When the printer is out of ribbon or label, the ON-LINE LED will not come on and the ERROR LED will flash. Reload the ribbon or media without turning off the printer. Press the FEED button a few times until the ON-LINE LED illuminates, the printing job will be resumed without data loss.***
- ***Please refer to videos on [TSC YouTube](#) or driver CD.***

3.4 Loading Media in Peel-off Mode (Option)

1. Please refer to section 3.3 to loading the media and to calibrate the sensor first.
2. Remove the foremost one or two labels from the liner.

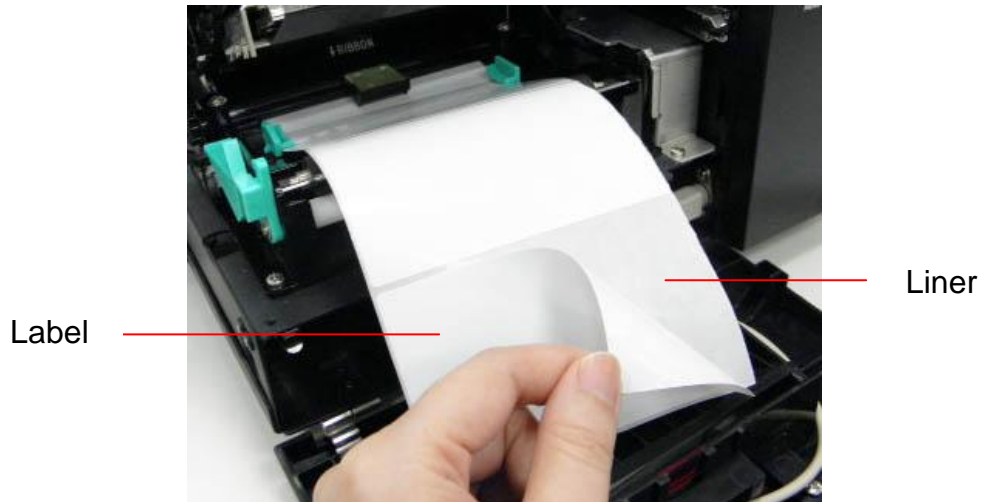

3. Pull the print head release lever to feed the liner between the platen and the white peel-off roller.

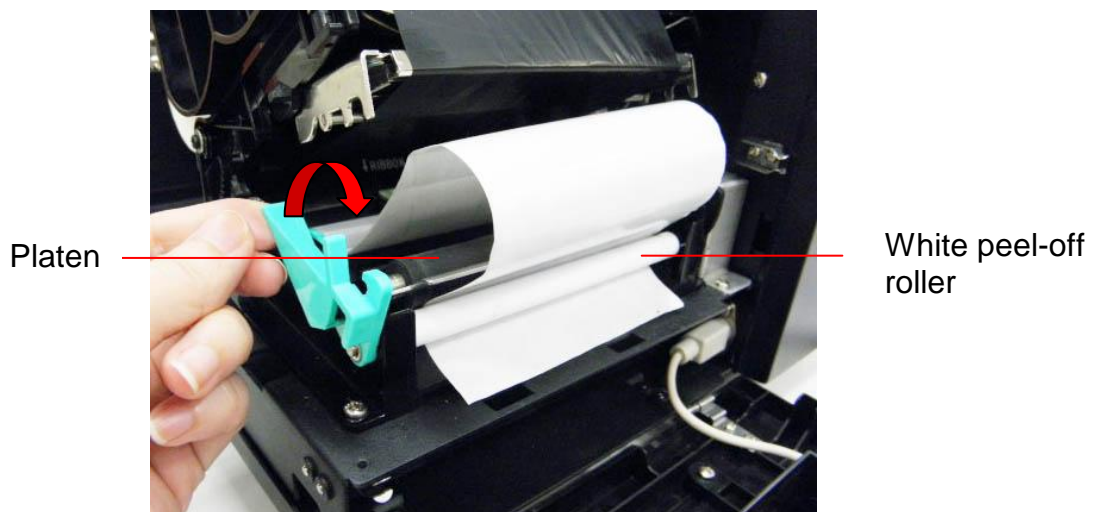

4. Feed the liner through the liner opening in the front panel.

Liner opening

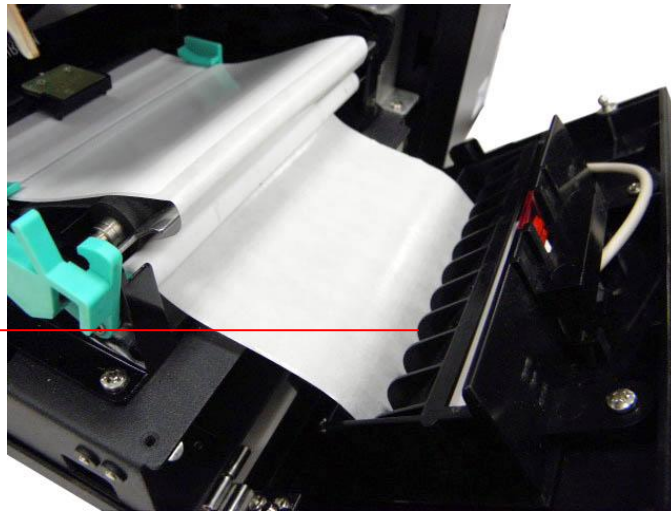

5. Close the print head, front panel and printer cover.

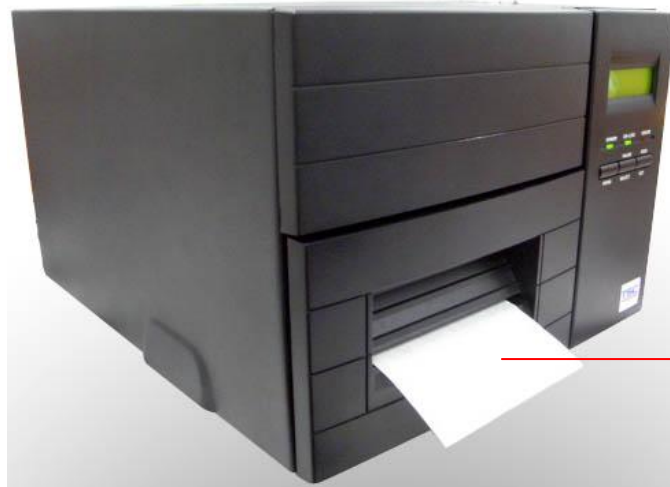

Liner

6. Set the “post-print action” to “peel”. Peeling will automatically start. Press the FEED button to test.

Label

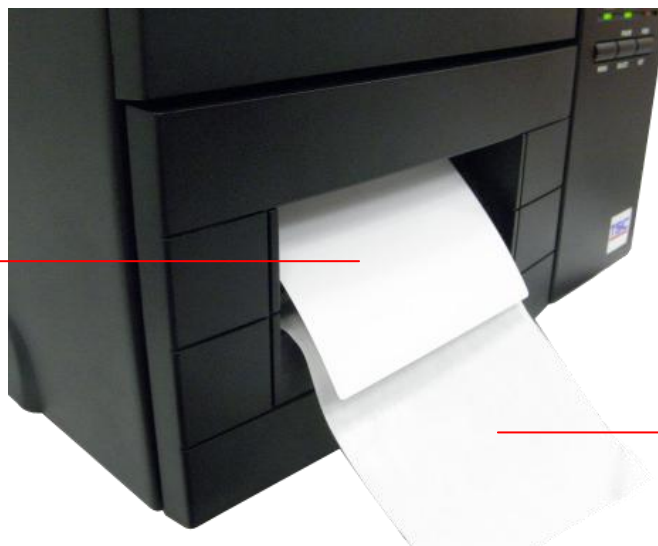

Liner

Note: Please calibrate the gap/black mark sensor when changing media.

3.5 Loading Media in Cutter Mode (Option)

1. Please refer to section 3.3 to loading the media.
2. Install the label so that it goes (when using an external label roll mount: through the label feed slot) in the direction of the  label and under the ribbon mechanism. Feed the label through the cutter opening.
3. Adjust the label guide to fit the width of the media.
4. Engage the printer carriage.
5. Close the printer cover and front panel.
6. Use “Diagnostic Tool” to set the media sensor type and calibrate the selected sensor. And set the “post-print action” to “cutter”.



Note:

- **Please calibrate the gap/black mark sensor when changing the media.**
- **When the printer is out of ribbon or label, the ON-LINE LED will not come on and the ERROR LED will flash. Reload the ribbon or media without turning off the printer. Press the FEED button a few times until the ON-LINE LED illuminates, the printing job will be resumed without data loss.**
- **Cutter module specification:**
 - **Rotary regular cutter**
 - **Paper thickness: Min. 0.12mm, 500,000 cuts**
 - **Max. 0.20mm, 250,000 cuts**
 - **Rotary heavy duty cutter**
 - **Paper thickness: Min. 0.12mm, 500,000 cuts**
 - **Max. 0.25mm, 250,000 cuts**
- **Except for the linerless cutter, all regular/heavy duty/care label cutters DO NOT cut on media with glue.**

4. POWER-ON UTILITIES

There are three power-on utilities to set up and test the printer hardware. These utilities are activated by pressing the **FEED** or **PAUSE** button and turning on the printer power simultaneously. The utilities are listed below:

1. Self test
2. Gap sensor calibration
3. Printer initialization

4.1 Self Test Utility

Install the label first. Press the **FEED** button and then turn on the printer power. Do not release the **FEED** button until the printer feeds labels. The printer performs the following:

1. Calibrate label pitch
2. Print out thermal print head check pattern
3. Print the internal settings
4. Enter dump mode

To initiate the self test mode, hold down the **FEED** button and activate the printer power simultaneously. The printer will calibrate the label length. If the label gap is not detected within 7", the printer stops feeding labels and the media is regarded as continuous paper. In self test, a check pattern is used to check the performance of the thermal print head. Following the check pattern, the printer prints its internal settings as listed below:

Self-test printout	
<pre> PRINTER INFO. XXXXXXXX Version: X.XX SERIAL NO.: MILAGE(m): 0 CHECKSUM: XXXXXX SERIAL PORT: 9600,N,8,1 CODE PAGE: 850 COUNTRY CODE: 001 SPEED: 6 INCH DENSITY: 8.0 SIZE: 4.00 , 6.06 GAP: 0.10 , 0.00 TRANSPARENCE: X HOST NAME: PS-FF02A4 MAC ADDRESS: 00-1B-82-FF-02-A4 DHCP ENABLED: YES IP ADDRESS: 0.0.0.0 SUBNET MASK: 0.0.0.0 DEFAULT GATEWAY: 0.0.0.0 ***** FILE LIST: DRAM FILE: 0 FILE(S) FLASH FILE: 0 FILE(S) PHYSICAL DRAM: XXXX KBYTES AVAILABLE DRAM: XXXX KBYTES FREE PHYSICAL FLASH: XXXX KBYTES AVAILABLE FLASH: XXXX KBYTES FREE END OF FILE LIST ***** </pre>	<ul style="list-style-type: none"> Model name and F/W version Serial no. Printed mileage (meter) Firmware checksum Serial port configuration Code page Country code Print speed (inch/sec) Print darkness Label size (inch) Gap distance (inch) Gap/black mark sensor sensitivity Numbers of download files Total & available memory space Print head check pattern

Self-test printout (with printer firmware V7.0 and later version)

```

-----
SYSTEM INFORMATION
-----
MODEL: xxxxxx
FIRMWARE: X.XX
CHECKSUM: xxxxxxxx
S/N: xxxxxxxxxxxx
TCF: NO
DATE: 1970/01/01
TIME: 00:04:18
NON-RESET: 110 m (TPH)
RESET: 110 m (TPH)
NON-RESET: 0 (CUT)
RESET: 0 (CUT)
-----
    
```

Model name
 F/W version
 Firmware checksum
 Printer S/N
 TSC configuration file
 System date
 System time
 Printed mileage (meter)
 Cutting counter

```

-----
PRINTING SETTING
-----
SPEED: 5 IPS
DENSITY: 8.0
WIDTH: 4.00 INCH
HEIGHT: 4.00 INCH
GAP: 0.00 INCH
INTENSION: 5
CODEPAGE: 850
COUNTRY: 001
-----
    
```

Print speed (inch/sec)
 Print darkness
 Label size (inch)
 Gap distance (inch)
 Gap/black mark sensor intension
 Code page
 Country code

```

-----
Z SETTING
-----
DARKNESS: 16.0
SPEED: 4 IPS
WIDTH: 4.00 INCH
TILDE: 7EH (~)
CARET: 5EH (^)
DELIMITER: 2CH (,)
POWER UP: NO MOTION
HEAD CLOSE: NO MOTION
-----
    
```

ZPL setting information
 Print darkness
 Print speed (inch/sec)
 Label size
 Control prefix
 Format prefix
 Delimiter prefix
 Printer power up motion
 Printer head close motion

Note:
 ZPL is emulating for Zebra® language.

```

-----
RS232 SETTING
-----
BAUD: 9600
PARITY: NONE
DATA BIT: 8
STOP BIT: 1
-----
    
```

RS232 serial port configuration

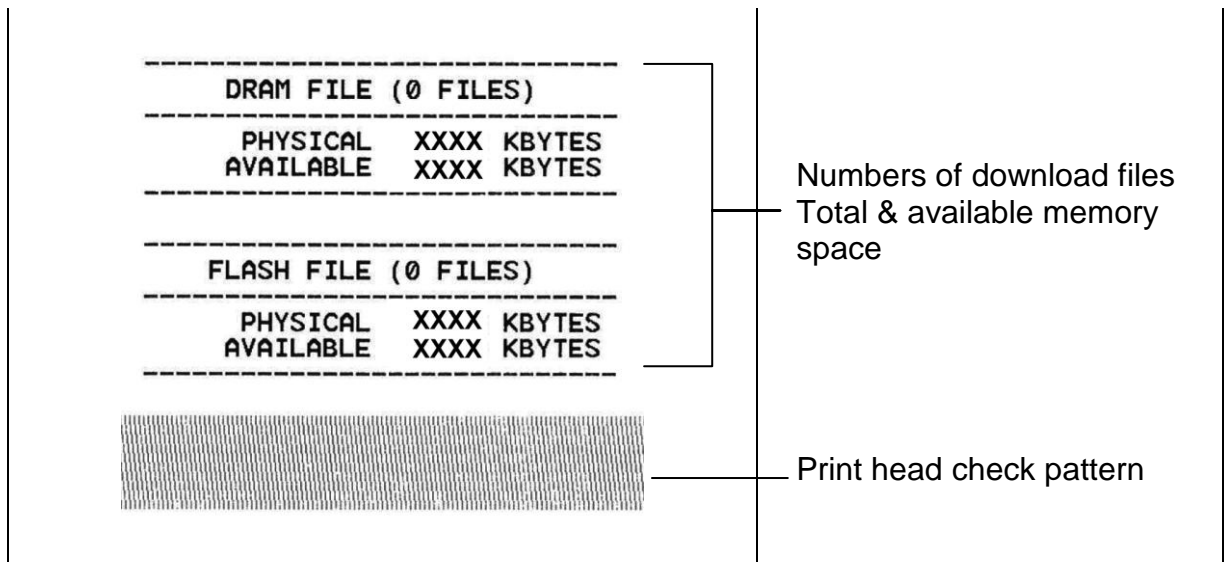

When the self test is completed, the printer enters the dump mode. Please turn the printer's power off and then on again to resume normal printing.

Note:

The physical flash memory on board is 4MB respectively. Due to system firmware will occupy 1.5MB, so total available flash memory space for downloads is 2.5MB bytes.

The DRAM on board is 8MB respectively. For DRAM, system and image buffer will occupy it, so total available DRAM for downloads will be 256 K bytes.

Dump Mode

After the self test, the printer enters the dump mode. In this mode, any characters sent from the host computer will be printed in two columns, as shown. The characters received will be shown in the first column, and their corresponding hexadecimal values, in the second. This is often helpful to users for the verification of programming commands or debugging of printer programs. Reset the printer by turning the **POWER** switch off and on.

```

*****
NOW IN DUMP MODE

DOWNLOAD "DE 44 4F 57 4E 4C 4F 41 44 20 22 44 45
MO2.BAS" SI 4D 4F 32 2E 42 41 53 22 0D 0A 53 49
ZE 4.00,5.00 5A 45 20 34 2E 30 30 2C 35 2E 30 30
CLS SPEED 0D 0A 43 4C 53 0D 0A 53 50 45 45 44
1.5 DENSIT 20 31 2E 35 0D 0A 44 45 4E 53 49 54
Y 10 DIRECT 59 20 31 30 0D 0A 44 49 52 45 43 54
ION 0 SET C 49 4F 4E 20 30 0D 0A 53 45 54 20 43
UTTER OFF S 55 54 54 45 52 20 4F 46 46 0D 0A 53
ET DEBUG LAB 45 54 20 44 45 42 55 47 20 4C 41 42
EL REFERENC 45 4C 0D 0A 52 45 46 45 52 45 4E 43
E 0,0 A=100 45 20 30 2C 30 0D 0A 41 3D 31 30 30
0 Y=100 FO 30 0D 0A 59 3D 31 30 30 0D 0A 46 4F
R I=1 TO 3 52 20 49 3D 31 20 54 4F 20 33 0D 0A
BARCODE 100, 42 41 52 43 4F 44 45 20 31 30 30 2C
Y, "39",96,1, 59 2C 22 33 39 22 2C 39 36 2C 31 2C
0,2,4,STR$(A 30 2C 32 2C 34 2C 53 54 52 24 28 41
) A=A+1 Y= 29 0D 0A 41 3D 41 2B 31 0D 0A 59 3D
Y+150 NEXT 59 2B 31 35 30 0D 0A 4E 45 58 54 0D
PRINT 1 EO 0A 50 52 49 4E 54 20 31 0D 0A 45 4F
P DEMO2 50 0D 0A 44 45 4D 4F 32 0D 0A

```

4.2 Gap Sensor Calibration Utility

This utility is used to calibrate the sensitivity of the gap sensor. Users may have to calibrate the gap sensor on two occasions:

1. Changing to a new type of label media.
2. Initializing the printer.

Note: The ERROR LED may flash if gap sensor is not calibrated properly.

Please follow the steps below to calibrate the gap sensor:

1. Turn off the printer power and install blank labels (without any logo or character) on the printer.
2. Hold down the **PAUSE** button and turn on the printer power.
3. Release **PAUSE** button when the printer feeds labels. **Do not turn off the printer power** until the printer stops and the two green LEDs light on.

Note: Black mark sensor has fixed sensitivity. It is no need to calibrate the black mark sensor

4.3 Printer Initialization

Printer initialization clears all downloaded files resident in the flash memory and sets printer parameters to default values.

Please follow the steps below to initialize the printer:

1. Turn off the printer power.
2. Hold down the **PAUSE** and **FEED** buttons and turn on the printer power.
3. Do not release the buttons until the three LEDs flash in turn.

Parameter	Default setting
Speed	50.8 mm/sec(2 ips)(203DPI) 38.1 mm/sec(1.5 ips)(300DPI)
Density	8
Label width	4" (101.6 mm)
Label height	4" (101.6 mm)
Sensor type	Gap sensor
Gap setting	0.12" (3.0 mm)
Print direction	0
Reference point	0,0 (upper left corner)
Offset	0
Print mode	Tear Mode
Serial port settings	9600 bps, none parity, 8 data bits, 1 stop bit
Code page	850
Country code	001
Clear flash memory	Yes
Shift X	0
Shift Y	0
Gap sensor sensitivity	8
LCD Language	ENGLISH
IP address	DHCP

Note:

- **Printing method (thermal transfer or thermal direct printing) will be set automatically at the activation of printer power.**
- **Download files will be deleted after printer initialization.**
- **Sensor calibration is required after printer initialization before printing labels.**

5. DIAGNOSTIC TOOL

TSC's Diagnostic Utility is an integrated tool incorporating features that enable you to explore a printer's settings/status; change a printer's settings; download graphics, fonts and firmware; create a printer bitmap font; and send additional commands to a printer. With the aid of this powerful tool, you can review printer status and settings in an instant, which makes it much easier to troubleshoot problems and other issues.

5.1 Start the Diagnostic Tool

1. Double click on the Diagnostic tool icon  `DiagTool.exe` to start the software.
2. There are four features (Printer Configuration, File Manager, Bitmap Font Manager, Command Tool) included in the Diagnostic utility.

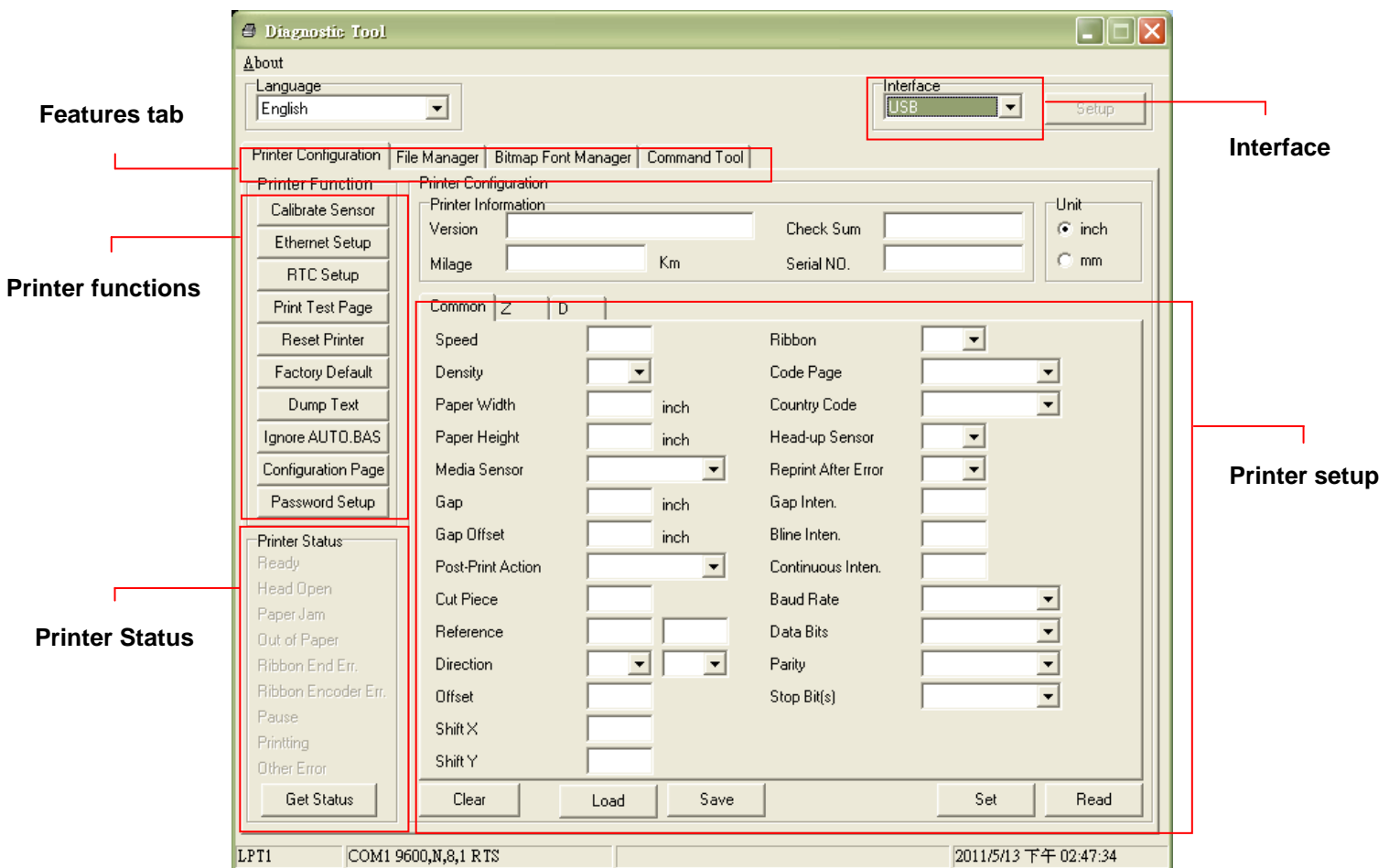

5.2 Printer Function

1. Select the PC interface connected with bar code printer.
2. Click the “Function” button to setting.
3. The detail functions in the Printer Function Group are listed as below.

Printer Function	Function	Description
Calibrate Sensor	Calibrate Sensor	Calibrate the sensor specified in the Printer Setup group media sensor field
Ethernet Setup	Ethernet Setup	Setup the IP address, subnet mask, gateway for the on board Ethernet
RTC Setup	RTC Time	Synchronize printer Real Time Clock with PC
Print Test Page	Print Test Page	Print a test page
Reset Printer	Reset Printer	Reboot printer
Factory Default	Factory Default	Initialize the printer and restore the settings to factory default.
Dump Text	Dump Text	To activate the printer dump mode.
Ignore AUTO.BAS	Ignore AUTO.BAS	Ignore the downloaded AUTO.BAS program
Configuration Page	Configuration Page	Print printer configuration
Password Setup	Password Setup	Set the password to protect the settings

Note:
For more information about Diagnostic Tool, please refer to the diagnostic utility quick start guide in the CD disk \ Utilities directory.

6. TROUBLESHOOTING

The following guide lists some of the most common problems that may be encountered when operating the bar code printer. If the printer still does not function after all suggested solutions have been invoked, please contact the Customer Service Department of your purchased reseller or distributor for assistance

Problem	Solution
Ribbon does not advance or rewind	The media and ribbon must be installed and close print head mechanism prior to turning on printer power.
Poor print quality	Clean the thermal print head. Adjust the print density setting. Ribbon and media are not compatible. Media thickness is over spec.
Power indicator does not illuminate	Check the power cord, see whether it is properly connected.
ON-LINE indicator is off, ERROR indicator is on	Out of paper or out of ribbon Calibrate the sensitivity of gap sensor. Rewind ribbon paper core is not installed.
Continuous feeding when printing labels	Calibrate the gap sensor.

7. MAINTENANCE

This session presents the clean tools and methods to maintain your printer.

1. Please use one of following material to clean the printer.

- Cotton swab (Head cleaner pen)
- Lint-free cloth
- Vacuum / Blower brush
- 100% ethanol

2. The cleaning process is described as following,

Printer Part	Method	Interval
Print Head	1. Always turn off the printer before cleaning the print head. 2. Allow the print head to cool for a minimum of one minute. 3. Use a cotton swab (Head cleaner pen) and 100% ethanol to clean the print head surface.	Clean the print head when changing a new label roll
Platen Roller	1. Turn the power off. 2. Rotate the platen roller and wipe it thoroughly with 100% ethanol and a cotton swab, or lint-free cloth.	Clean the platen roller when changing a new label roll
Tear Bar/Peel Bar	Use the lint-free cloth with 100% ethanol to wipe it.	As needed
Sensor	Compressed air or vacuum	Monthly
Exterior	Wipe it with water-dampened cloth	As needed
Interior	Brush or vacuum	As needed

Note:

- Do not touch printer head by hand. If you touch it careless, please use ethanol to clean it.
- Please use 100% Ethenol. DO NOT use medical alcohol, which may damage the printer head.
- Regularly clean the print head and supply sensors once change a new ribbon to keep printer performance and extend printer life.

Appendix A Menu Control Flowchart (Option)

The following shows the control flowchart of the menu.

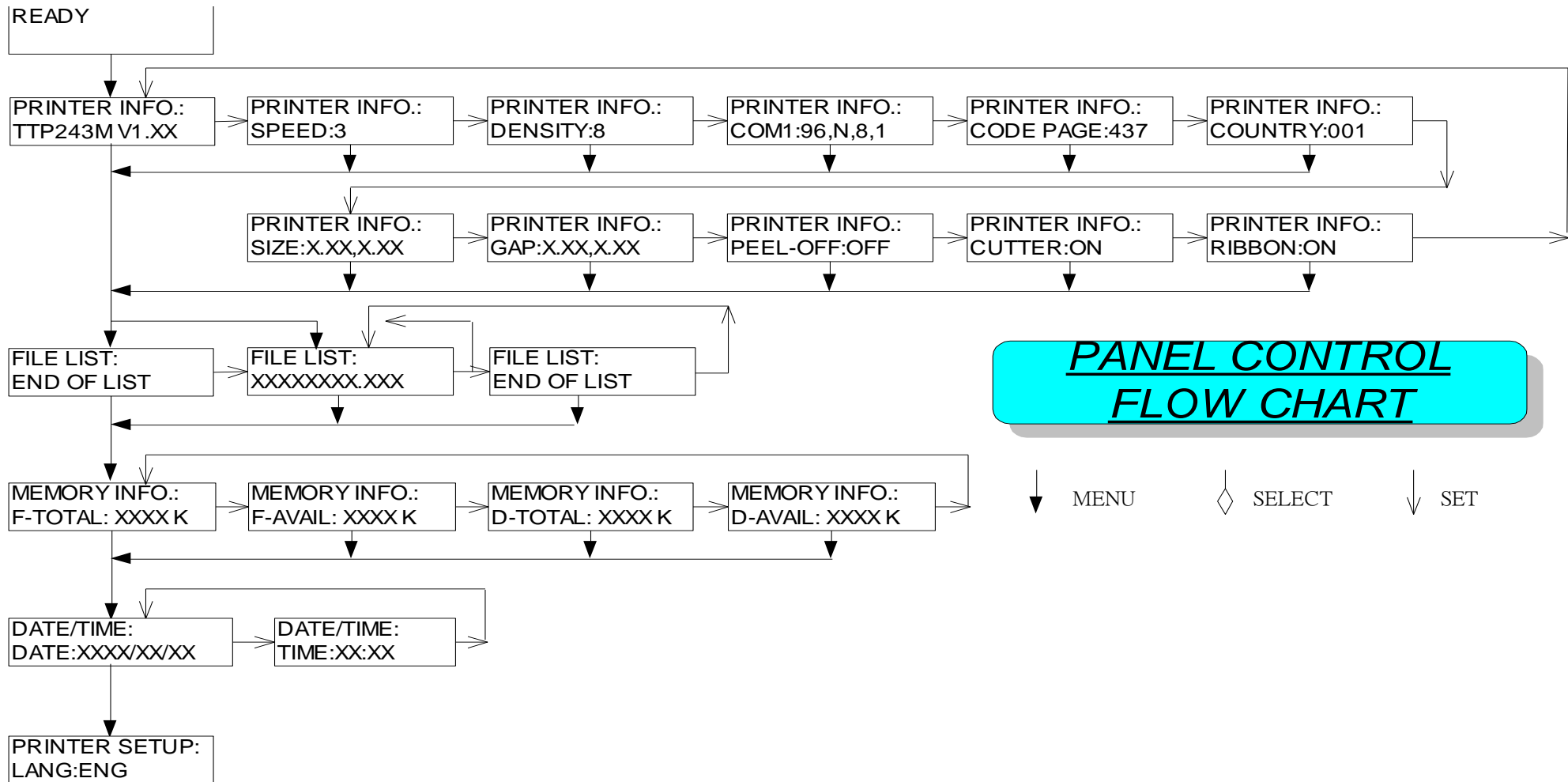

(Continued on next page)

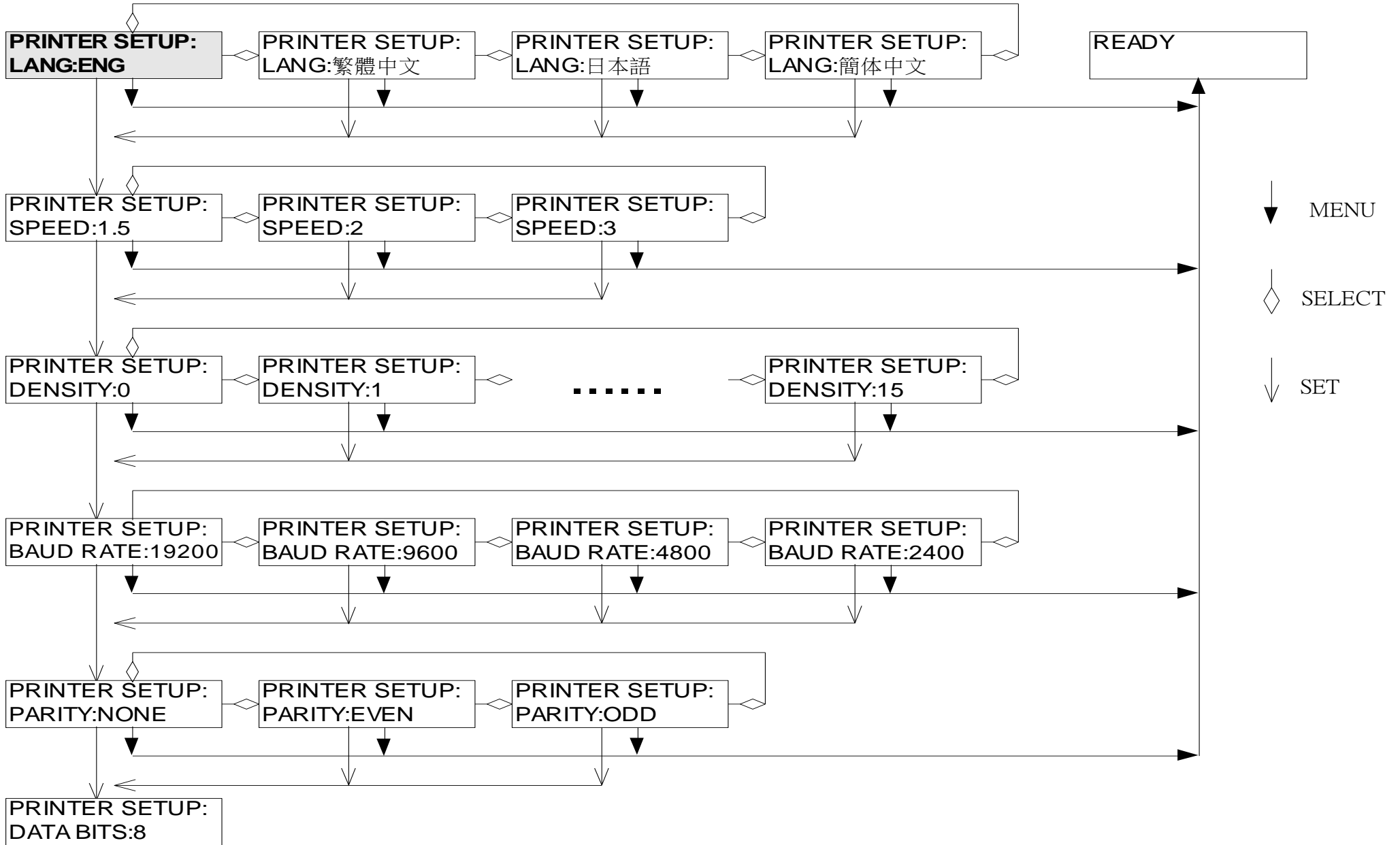

(Continued on next page)

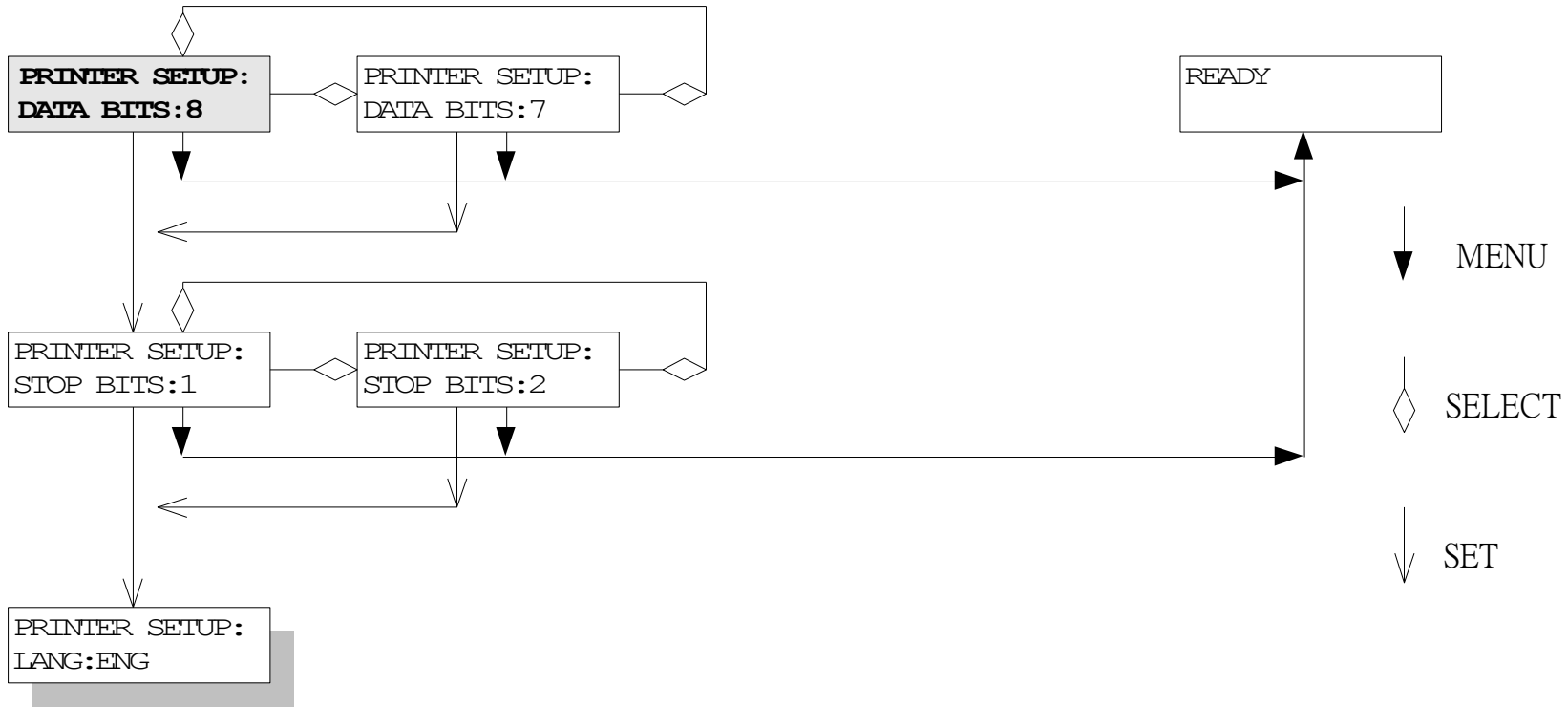



TSC Auto ID Technology Co., Ltd.

Corporate Headquarters

9F., No.95, Minquan Rd., Xindian Dist.,
New Taipei City 23141, Taiwan (R.O.C.)

TEL: +886-2-2218-6789

FAX: +886-2-2218-5678

Web site: www.tscprinters.com

E-mail: printer_sales@tscprinters.com

tech_support@tscprinters.com

Li Ze Plant

No.35, Sec. 2, Ligong 1st Rd., Wujie Township,
Yilan County 26841, Taiwan (R.O.C.)

TEL: +886-3-990-6677

FAX: +886-3-990-5577